

MULTI-LIP CARTRIDGE SEAL *FOR CHALLENGING APPLICATIONS*

Viscous substances such as syrups, tars, thick oils, resins, and glues prove to be challenging for most mechanical seals. Lip seal designs have been the go-to option for these processes that have centipoise values well above the normal range for seal face operation. Flexaseal now brings our sealing expertise to this demanding sector of fluid management.

The MLC3 cartridge seal achieves optimum pumping rates at lower speeds with fewer sealing issues than products currently in the field and requires virtually no seal support system.

- Machined lip seals with deflected lip geometry ensures reliable sealing while producing a smaller footprint compared to competitor designs. This smaller footprint reduces parasitic torque and heat generation.
- Integral anti-rotation rings within the lip seals provide high static sealing ability.
- PTFE-ML compounds suitable for aggressive chemicals, as well as EU, GMP, and FDA compliance.
- Easy to install cartridge design.
- Easy field repairability using available spare parts kit.

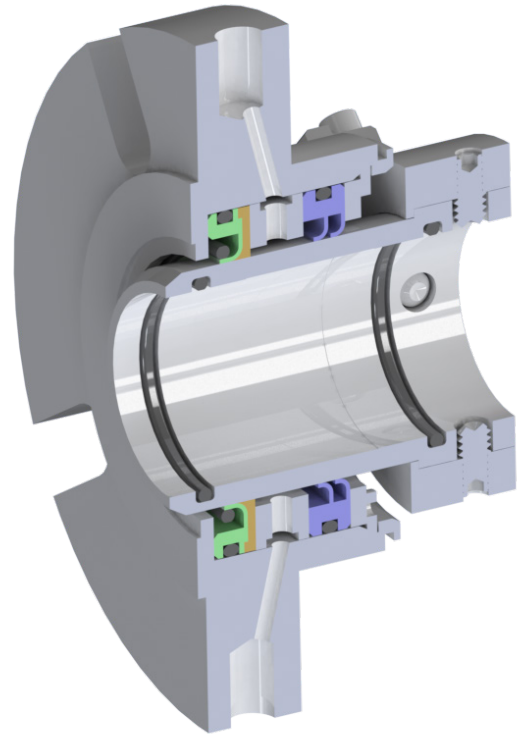

THE PTFE-ML ADVANTAGE

Axial Movement:	±.125"
Max. Runout:	±.020" TIR (typical) ±.025" TIR (low speeds)
Vacuum:	25mm Hg

MATERIALS OF CONSTRUCTION

Lip Seals	PTFE-ML proprietary compound
Sleeve	Sintered Silicon Carbide Hard Coated 316 SS upon request
Elastomers	FKM standard Other materials upon request
Lantern Ring	PTFE
Metallurgy	316 SS
Also available	<ul style="list-style-type: none"> • FDA-approved materials of construction • Energized O-ring or garter spring options

OPERATING PARAMETERS

Viscosities	up to 500,000 cps
Process Pressures	up to 300 psig (20.7 bar)
Temperatures with environmental control	-100° to 450°F (-73.3 to -267.7°C)
Surface Speeds	Dry running: 3000 fpm (15.24 m/s) With environment control: 5000 fpm (25.4 m/s)

Maximum viscosity/temperatures/speed/pressure indicates operating extremes independently and does not imply the seal will function at these extremes at the same time.

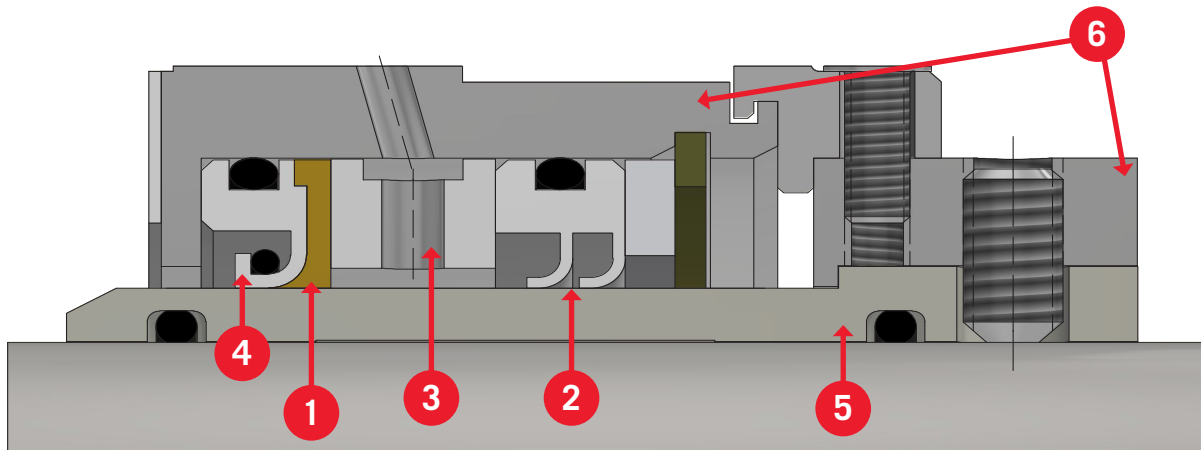

1. Single Lip Seal with anti-rotation ring and integrated back up ring:

Energized front lip prevents leakage when transitioning between high viscosity and high fluidity processes. Anti-rotation rings statically seal even under normal temperature cycling. The integral back up ring provides added lip support under higher pressures and potential pressure spikes.

2. Double Lip Seal with anti-rotation ring:

The PTFE-ML compound is formulated with a lower coefficient of friction, which coupled with the enhanced heat dissipation leads to a lower under-lip temperatures. Lower temps = lower seal and sleeve surface wear.

3. Lantern Ring:

Multifunctional PTFE ring provides additional bearing support as well as even dispersion of lubricant or barrier/buffer fluid around the lip seals.

4. Energized O-ring:

Front lip tolerates lower speeds and higher shaft runout. This design increases sealing viability with certain emulsifiers and fluid viscosity transitioning such as CIP applications.

5. Sleeve:

Sintered Silicon Carbide sleeve for durable wear and sealing surface. Inboard and outboard sleeve O-rings dampen vibration and aid in easy removal and repair.

6. 316 Stainless construction

of the drive collar and gland. Enhanced corrosion allowance as compared to 304 SS used in competitor designs.

ADDITIONAL MLC3 SEAL CONFIGURATIONS

Tandem configuration with Lubricant or Purge.

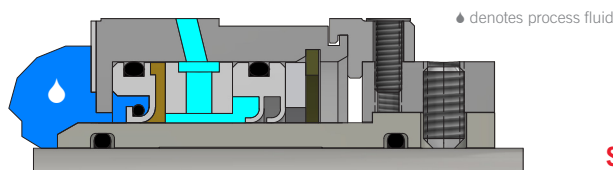

Dual Seal or Vacuum configuration with Barrier / Buffer Fluid.

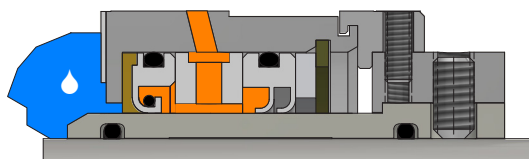

Seals can be grease packed with **Magnalube®-G** or **Molykote™111** upon request.